

XBT series user's

Version of V1.1

Date, 2024.07.24

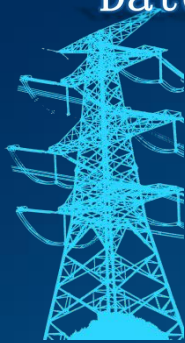
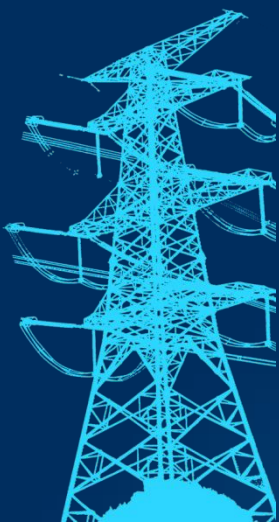

catalogue

preface	1
disclaimer	1
Copyright Statement	1
Technical changes	1
conformally connected space	1
safe	2
The symbols used	2
matters need attention	2
Personnel with electrical qualifications	3
Chapter 1 Arrival Inspection and Storage	4
1.1 Transportation	4
1.2 Receiving and checking the equipment	4
1.3 Packaging of the module	4
1.4 Storage	4
Chapter II Product Overview	6
2.1 Product naming	6
2.2 Appearance and composition of the products	6
2.3 Overall dimensions	7
2.4 Technical parameters	8
Chapter III: System Installation	10
3.1 Tools	11
3.2 Installation environment	12
3.3 Mechanical installation	13
3.4 Electrical connection	13
3.4.1 Power terminal	13
3.4.2 Communication port	14
3.4.3 Single-machine power distribution	18
3.4.4 Distribution and distribution	19
3.5 Control of the intelligent capacitor	23
3.5.1 Ordinary capacitor (external relay)	23
3.5.2 Intelligent capacitors	24
Chapter 4: Test run of the single machine	26
4.1 Check again	26
4.2 Power on the equipment	26
4.3 Equipment is shut down	27
4.3.1 Shutdown	27
4.3.2 Power-off	28
4.4 Manual / automatic operation	28
Chapter 5 Trial operation	29
5.1 Check again	29
5.2 Power on the equipment	29
5.3 Equipment is shut down	30
5.4 Manual / automatic operation	31

Chapter 6 A 1.8-inch screen menu	32
Chapter 7 Cabinet 7-inch HMI	36
Chapter VIII Maintenance and Maintenance	37
8.1 Attention before maintenance	37
8.2 Content and cycle of daily maintenance	37
8.3 Complete maintenance steps	38
Chapter 9. Common troubleshooting	39
appendix:	42
Background forwarding description and interface definition	42

preface

To help you better use the product and protect you and the product safety, please carefully read and understand the relevant security information and about the equipment and user manual information before operating this product.

disclaimer

Following the contents of the user manual is a prerequisite for safe operation, and also a prerequisite for achieving the described performance features and product functions;

Our company shall not bear the responsibility for the material loss, economic loss or personal injury caused by the neglect of the product information;

Copyright Statement

We reserve the final interpretation right of this manual, prohibiting the reproduction, modification or dissemination of the contents of this manual without permission;

Technical changes

Please read and understand the information related to the product;

Please keep this manual during the service period of the product to avoid emergencies;

As the product is constantly updated and upgraded, and not without notice;

conformally connected space

Within the shelf life of the product, due to the quality problems of the product can enjoy free after-sales service;





Do not attempt to disassemble, repair, modify, upgrade the equipment, otherwise all warranty services will be invalid.

safe

This instruction is important for the installation and use of reactivity reactive power generator (SVG) and active filter (APF), and ignoring these instructions may cause physical harm to you. The following safety information summarizes the safety measures required for the operation of the equipment and its components. Follow the safety tips and safety information to ensure your personal safety and avoid material and economic losses.

The symbols used

Safety information is marked with a symbol, according to the danger degree, the danger level is shown as follows:

 pay attention to	Please always pay attention to possible dangerous situations, if not careful, may lead to mild injury.
 take care	Please always pay attention to the dangerous situations that may occur, if not careful, may lead to moderate injury.
 warn	Please always pay attention to possible dangerous situations, if not careful, may lead to serious injury.
 danger	Please be careful of electrical hazards.

matters need attention

When operating the electrical equipment, some parts of the equipment will inevitably produce a dangerous voltage. If not handled properly, serious physical injury or equipment damage may occur.

- ◆ It is strictly prohibited to access the power grid at will without understanding, so as not to cause equipment damage and personal safety harm!
- ◆ Improper use will damage the static reactive power generator and the connected equipment;
- ◆ All system installation or routine maintenance must be operated in the case of power failure;
- ◆ It is strictly prohibited to place combustible material near the equipment or install it in the environment containing explosive gas, otherwise there is a risk of fire or even explosion;
- ◆ Ensure that the input power is completely disconnected, installation, wiring operation, otherwise the risk of electric shock; after power on, never touch other parts of the equipment except the LCD screen;
- ◆ Bare cables, power terminal joints, and ungrounded live equipment may cause electric shock. Please ask

the electrical engineer or professional technician to confirm that the equipment is fully grounded and determine the live parts of the joints and components; please use suitable safety protective clothing and test tools and follow the safety operation specifications;

- ◆ No maintenance of equipment in working condition;
- ◆ When maintaining the product, be sure to cut off the main circuit and wait for at least 15 minutes to ensure that the AC side voltage drops to 0V and the internal capacitor is fully discharged;
- ◆ In wet conditions, the resistance of the human body will drop, at this time there may be a dangerous large current through the human body, so do not maintain and install equipment in a wet place. When it is impossible to avoid working under such conditions, stand on a dry rubber mat or dry board and use insulating gloves to keep the clothes dry and work with a companion.

Personnel with electrical qualifications

To avoid personal injury and material loss, only professional electrical qualified personnel are allowed to operate on the equipment and its components, assembly, systems, and current circuits, and they must have the following knowledge:

- ◆ National and international regulations on electrical safety accidents;
- ◆ Power supply technical standard of safety prevention system and national standard of low-voltage electrical safety technical specification;
- ◆ Installation, commissioning, operation, disconnect, grounding and marking of electrical equipment;
- ◆ Basic requirements for personal protection.

Chapter 1 Arrival Inspection and Storage

1.1 Transportation

Each set of equipment is generally transported through carton packaging (default carton, optional wooden box). The carton has buffer foam cotton and other protective items, but it can not be inverted or tilted in the process of transportation and handling, so as to ensure that the filter is not to be damaged in the process of movement.

1.2 Receiving and checking the equipment

The equipment has been professionally tested and inspected before leaving the factory, and is prepared according to the requirements of safe transportation. However, during the long-distance transportation, the fixed parts on the equipment may still become loose due to vibration turbulence and other reasons. Therefore, after receiving the equipment, please conduct the following inspection:

- ◆ After the equipment delivery arrives at the site, please check the goods according to the delivery list. If there are any abnormal conditions, such as damaged packaging, obvious deformation of equipment, inconsistent equipment quantity and the delivery list, please sign the carrier for confirmation and contact the manufacturer immediately;
- ◆ When removing the equipment package, please pay attention to avoid violent removal. When you use scissors, pliers, etc. to remove the packaging, please be careful to avoid scratching and damage to the equipment;
- ◆ Check whether there is any external damage on the equipment, such as panel scratches, paint drop, depression, etc., and observe whether there are falling components and loose wiring in the equipment. In case of transportation damage should request logistics claim, need assistance in the claim process, please contact the company;
- ◆ Check the specifications and models. We have striking nameplate labels on our equipment shell, which clearly describes the equipment model, rated capacity and other information. Please work carefully again to check the invoice and whether the goods are consistent with the delivery list.

1.3 Packaging of the module

The module packaging is divided into cartons and wooden boxes, generally the default carton. If you need a wooden box package, please note it in advance.

1.4 Storage

- ◆ Equipment, packaging to avoid long-term outdoor storage, can be stored indoors for 6 months (from the date of delivery), if you need to store for a longer time, order can propose to the company to make a longer storage time packaging;

- ◆ If the equipment is not installed and used immediately, the equipment should be placed in a dry, ventilated, no dust, no corrosive material warehouse, and no strong mechanical vibration and magnetic field action in the warehouse;
- ◆ Storage ambient temperature: (-45°C ~70°C), relative humidity of air: (5%~95%) (less than 25°C);
- ◆ When long-term storage is required, please regularly check to confirm whether the equipment packaging is moldy and damaged.

Chapter II Product Overview

2.1 Product naming

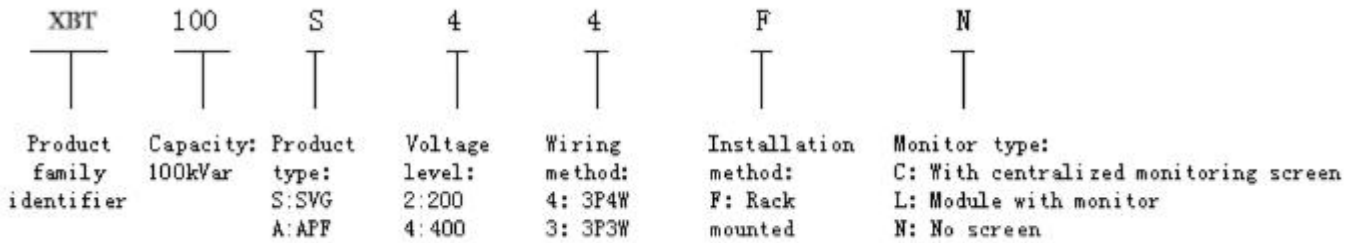

Example: Model "XBT 100S44FN" refers to SVG module of 100 kvar; Model "XBT 100A44FN" refers to APF module of 100A.

SVG product specifications: 35 kvar, 50 kvar, 75 kvar, 100 kvar;

APF product specifications: 50A, 75A, 100A, 150A.

2.2 Appearance and composition of the products

The XBT series is currently rack-mounted, and the following is the reference diagram for the 75 kvar / 100A, 100 kvar / 150A modules.

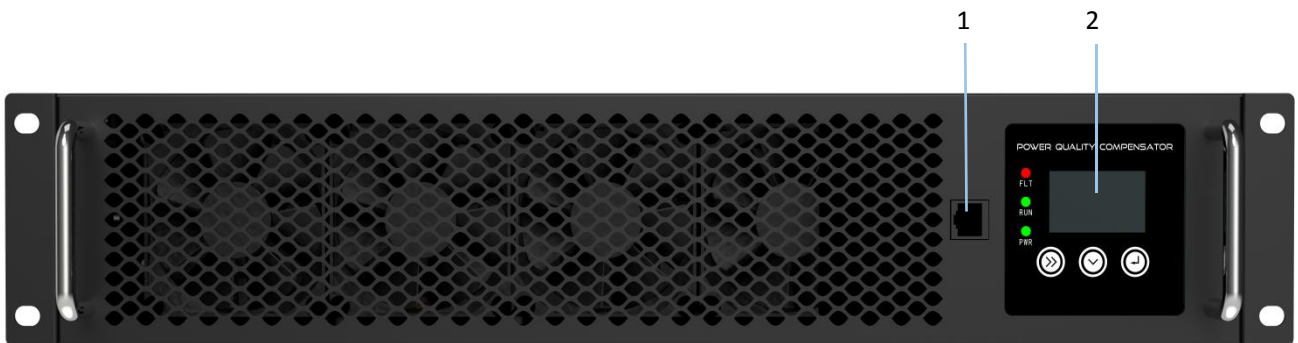

Figure 2-1 Front panel diagram of the module

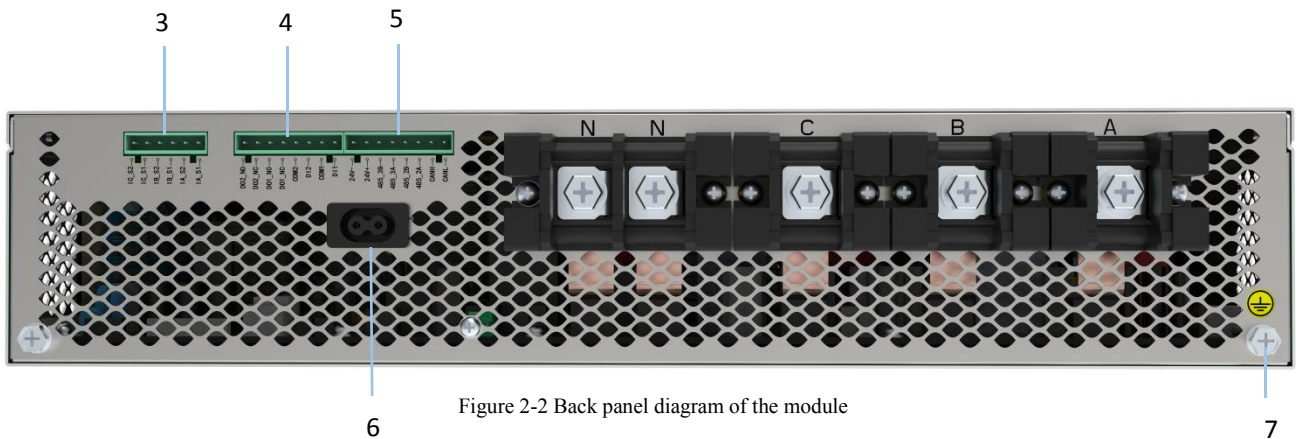

Figure 2-2 Back panel diagram of the module

order number	explain
1	COM debugging interface

2	1.8-inch display screen (optional)
3	CT signal port
4	Digital port
5	communication port
6	Debug the power interface (220V), 35 kvar / 50A, 50 kvar / 75A no
7	Ground wire interface, M6 screw
A、B、C、N	Power line interface

Note: The two terminals of N line are designed. When processing harmonics, N line should be designed according to 2 times the rated amount. The internal design is to meet the power density demand of 300A, and the external output needs to take 300A current. One terminal is the specification of 200A, which not only meets the safety requirements, but also meets the derating specification. The 35 kvar / 50A and 50 kvar / 75A have only one N wire interface, and the power terminal is not independently separated, so the combined terminal connector is adopted.

2.3 Overall dimensions

Take the screen module as an example, the screen module is of the same size as the module without the screen.

Rack type:

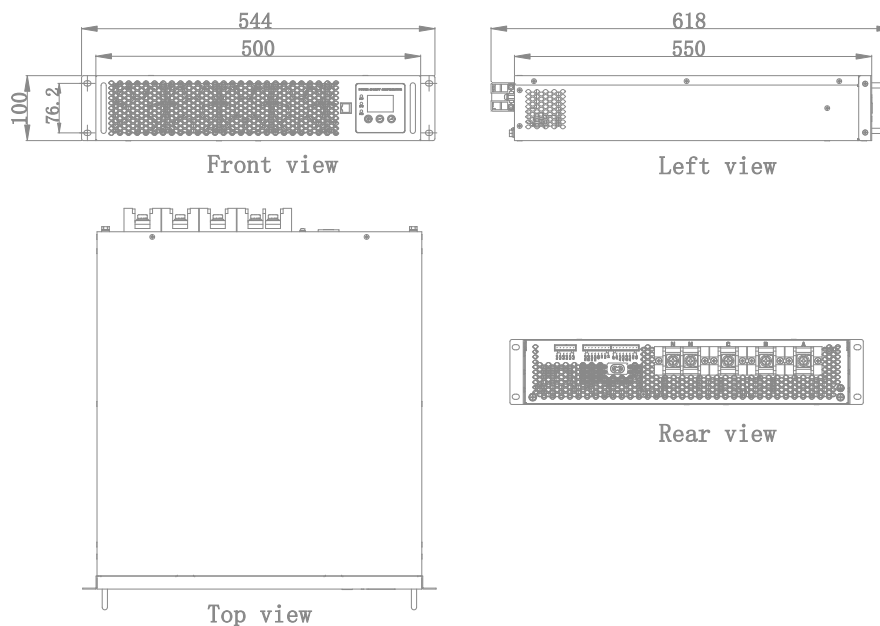
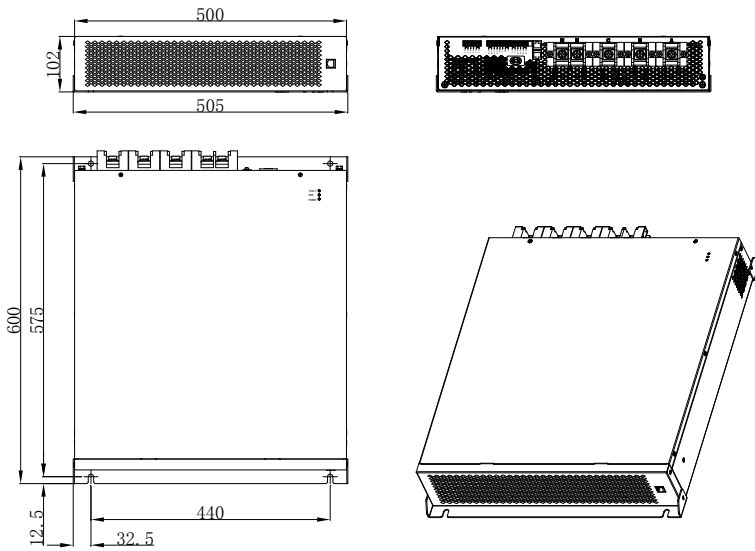

Figure 2-3 rack type dimensions

SVG/APF	Dimensions (WHD)	weight
35kvar/50A	440 × 88 × 425 mm	14kg
50kvar/75A	440 × 88 × 510 mm	17kg
75kvar/100A	500 × 100 × 550mm	27kg
100kvar/150A	500 × 100 × 550mm	30kg

wall mounting type:



SVG/APF	Dimensions (WHD)	weight
35kvar/50A	440 × 425 × 88 mm	14kg
50kvar/75A	440 × 510 × 88 mm	17kg
75kvar/100A	500 × 600 × 102mm	27kg
100kvar/150A	500 × 600 × 102mm	30kg

The following schematic diagram of the module in the cabinet can place up to 12 modules with a maximum capacity of 1200 kvar.

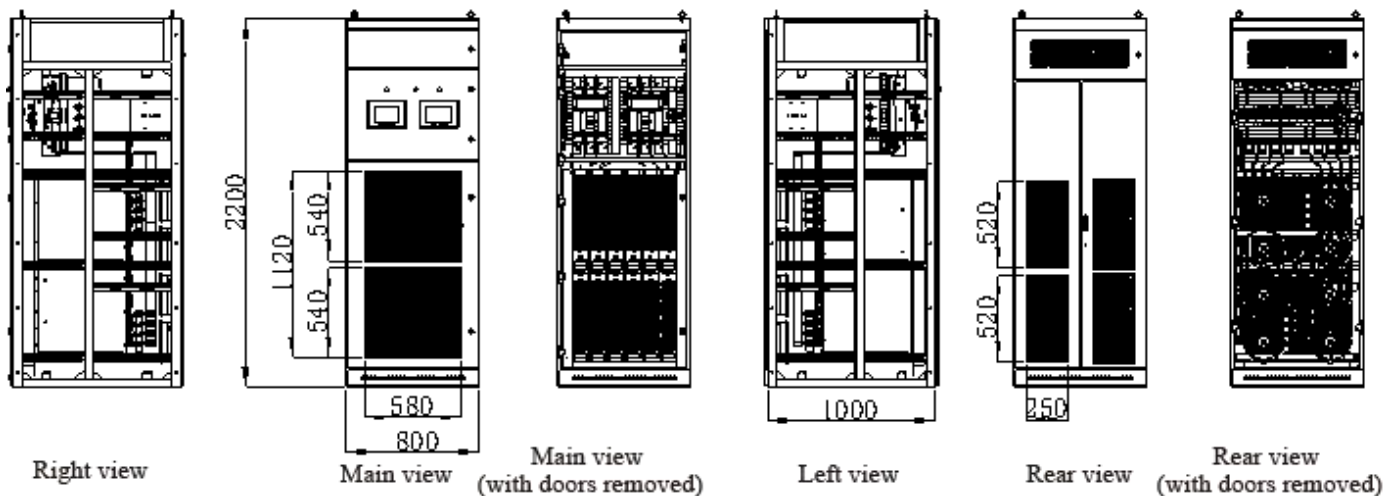





Figure 2-4 Schematic diagram of 1200 kvar complete cabinet

2.4 Technical parameters

Single module capacity	35kvar/50A	50kvar/75A	75kvar/100A	100kvar/150A
weight	14kg	17kg	27kg	30kg
Rated voltage (V)	200/400			
input voltage range	-20%~+20%			
frequency	50/60Hz (-10%~+10%)			
compensation range	Capacity, perceptual continuous adjustable			
CT way to install	Open or closed loop (recommended in parallel case)			
CT installation site	Grid side / load side			









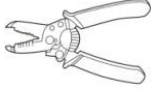

response time	≤10ms
wiring system	Three-phase three-line / three-phase four-wire
overload capacity	110% rated current and 1min at 120% rated current
THDU	< 10%
Circuit topology	Three-level topology
switching frequency	20 kHz
The number of machine	≤ 20
redundance	Any unit can become separate units
Unbalanced governance	Optional
Harmonic governance	Optional
show	Screen / 1.8 inch screen / external 7 inch screen (optional)
communication interface	RS485、CAN
Noise level	<56 dB max to <69 dB (depending on module or load condition)
above sea level	1% decrease is used for> 1500m per 100m increase
ambient temperature	Operating temperature: -25°C~55°C, drop over 45°C
	Storage temperature: -45°C~70°C
humidity	5% ~ 95% RH, with no condensation
cooling-down method	Intelligent air cooling
levels of protection	IP20
Module air volume	570 (CFM) /16m ³ (/min)

Chapter III: System Installation

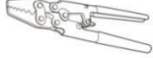
 <p>pay attention to</p>	<ul style="list-style-type: none"> ◆ All modules have the same signal interface, 75 kvar / 100A, 100 kvar / 150A power terminal has two N phase terminals, and both N phase terminals need wiring; ◆ The screen-less module is consistent with its installation and wiring mode; <p>The ◆ module can be monitored with a small 1.8-inch screen or a large 7-inch screen (optional).</p>
 <p>take care</p>	<ul style="list-style-type: none"> ◆ Provide sufficient air circulation in the installation environment. When the ambient temperature is high, please cool the equipment to some extent as needed; ◆ Follow the installation instructions in this manual and related accessories; ◆ Install the rack-type module, please install it horizontally. Try not to tilt, inverted and other directions for installation; ◆ Install the wall-mounted module, try to install the wall-mounted vertically, do not side hanging or upside down; ◆ Install vertical modules to avoid tilt and lodging installation.
 <p>warn</p>	<p>Because ignoring the installation instructions can easily cause damage to the equipment and may endanger personal safety in serious cases, please strictly abide by the following regulations:</p> <ul style="list-style-type: none"> ◆ Before starting work, disconnect and make sure it is not closed by the person and check that the equipment is power off! Temporary cover the adjacent live part with insulating material; ◆ In the process of operation and troubleshooting, please check whether there is a dangerous voltage in the environment in advance, and please close them if necessary; ◆ When working on the electrical system, please wear the protective clothing and protective equipment according to the applicable guidelines; ◆ Before connecting the equipment / components, keep ground and ensure the equipment is power off; ◆ Do not contact the exposed or peeled wire, the twisted wire should be equipped with wire sleeve; ◆ Dangerous voltage is possible in all circuit parts connected to the power supply / grid; ◆ Use a suitable line disconnecting switch / circuit breaker / fuse; ◆ Even after disconnection from the power supply / grid, dangerous voltage may still exist in the equipment or components (capacitor); ◆ Do not operate the equipment when the current transformer circuit is open; ◆ Do not make the equipment run at full load for a long time, and do not set the parameters beyond the limit value that the equipment can bear; ◆ Note the warning and safety identification of all documents related to the equipment; ◆ Please pay attention to all warnings and safety signs in the site environment.

3.1 Tools

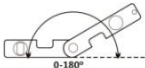
Prepare the tools that may be used for installation and wiring in advance. Only some tools that may be used are listed here for reference only.

order number	tool	description	function
1		churn drill	Wall hole
2		One-word screwdriver	Remove, install screws and wiring
3		Phillips screwdriver	Remove, install screws and wiring
4		connection cover cutting pliers	wire stripping
5		inner hexagon spanner	Fixed module
6		Press wire clamp	Press the communication and control the terminal wiring And the crimded CT extension cord
7		multimeter	Check the cable wiring, Whether the grounding is reliable
8		marker pen	The punch mark
9		band tape	measured range
10		levelling instrument	Ensure the module level
11		Insulating and protective gloves	Wear it when installing the machine

3.2 Installation environment

The following are our suggestions on the working and installation environment of the equipment. If our suggestions are not taken, the equipment will be prone to damage:

(1) Site requirements

- ◆ The equipment must be installed in the electrical control room, which must maintain a good ventilation environment;
- ◆ Air inlet and air outlet must have professional rain, dustproof, sand prevention treatment, necessary fire and rodent treatment;
- ◆ If there are serious dust (especially live dust) and fly ash problems on the installation site, it is recommended to specially protect the equipment to avoid the reduction of equipment efficiency, service life, failure and damage.

(2) Foundation requirements

- ◆ The installation surface must be smooth and dry, and the ground is strictly prohibited from standing water;
- ◆ Make sure that the ground does not shake horizontally, the plot is strong, and can withstand the weight of the device.

(3) space requirement

- ◆ Sufficient space should be reserved (at least 30cm) for heat dissipation;
- ◆ Equipment should be kept away from flammable and explosive articles and corrosive materials;
- ◆ Enough space should be reserved around the equipment for operation, wiring and future maintenance;
- ◆ The installation position must comply with the fire safety regulations.

(4) Work and environment requirements

- ◆ Operating with full load at altitude below 1500m; at 1500m-4000m, according to the national standard GB / T3859.2 for 100m;
- ◆ Humidity: 5~95%, no condensation;
- ◆ Ambient temperature: -25℃ ~55℃, drop over 45℃.
- ◆ Equipment as far as possible to avoid dealing with a strong impact load of machinery and equipment (such as: medium frequency furnace, high frequency furnace, etc.).



pay
attention to

If you need to use in the site of strong salt, strong acid and alkali and other strong corrosion equipment, communication with our company needs special instructions, if there is a special site requirements without an explanation of the product damage or can not be used, the company will not be responsible for!

3.3 Mechanical installation

For rack-type installation, the ears can be fixed on the mounting post of the cabinet (as shown below).

The armrest of the front panel of the module is only held as an auxiliary installation, and is not used for load-bearing!

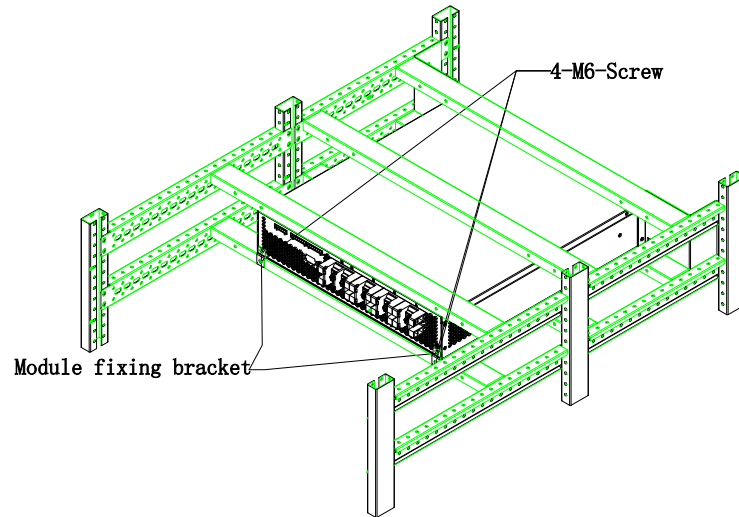



Figure 3-1 Schematic diagram of the module installation

3.4 Electrical connection

3.4.1 Power terminal

 warn	<ul style="list-style-type: none"> ◆ The wiring of the power terminal must be connected correctly, please be sure to check for many times: no leakage, no mixing, otherwise it may cause equipment failure or damage; ◆ Please keep the power terminal dry and can be protected if necessary; ◆ Power terminal is conductive material, do not touch by hand!
---	---

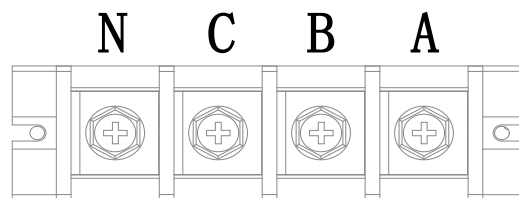

Figure 3-2 35 kvar / 50A, 50 kvar / 75A power terminal diagram

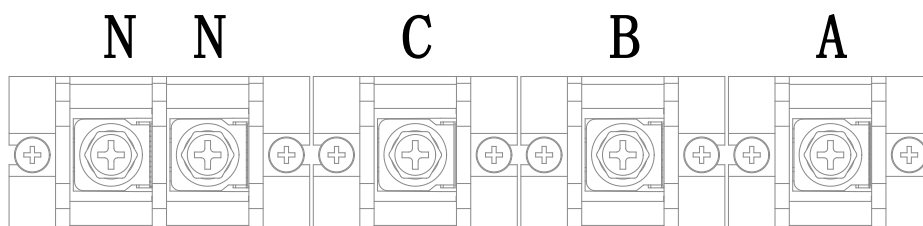

Figure 3-3 Power terminals of 75 kvar / 100A kar, 100 kvar / 150A

project	explain	Terminal screws	cable	remarks
A	Phase A input	M8	50mm ²	
B	Phase B input	M8	50mm ²	
C	Phase C input	M8	50mm ²	
N	N phase input	M8	50mm ²	Two N lines shunt
N	N phase input	M8	50mm ²	
PE	Ground wire access	M6	25mm ²	

3.4.2 Communication port

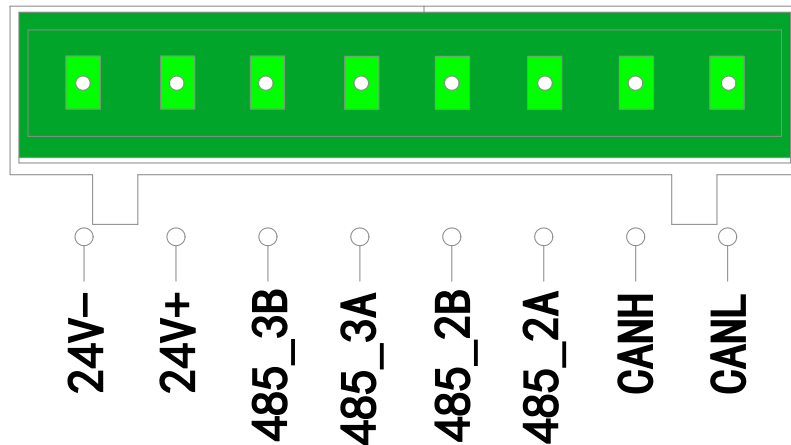

Figure 3-4 Communication port and definition diagram

name	definition	explain	remarks
CAN	CAN Communication network port	CAN_L-CAN_H: used for consolidation	
485	RS485 Communication network port	General: 485_3A-485_3B: Connect to the large screen Control capacitor: 485_3A-485_3B: connect the large screen to the capacitor or relay	Two road 485 “2A -2B”“3A -3B”
24Vdc	24Vdc output	Provide 24V DC to the external system	

3.4.3 Digital ports

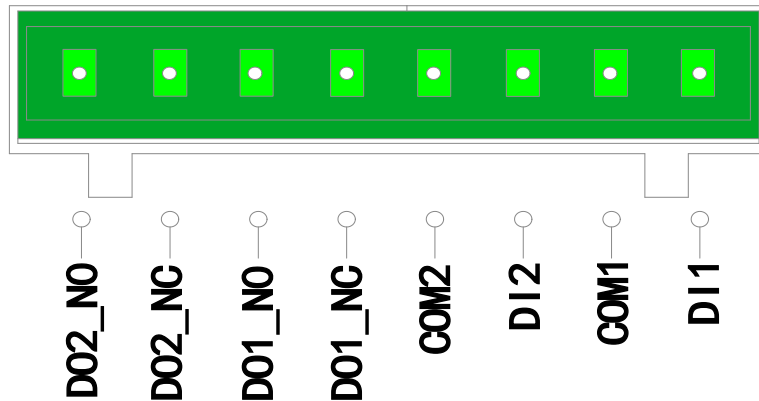

Figure 3-5 Digital port diagram

project		Terminal symbol	Description of terminal function	Electrical specifications
Digital port	digital input	DI1	Digital input to port 1 (Default is stop)	Light-coupled isolation input Input voltage: 9 ~ 24 Vdc Input impedance: 5k Ω
		COM 1		
		DI 2	Digital input to port 2	
		COM 2		
	numeric output	D01_NC	Relay output # 1 (Default is a fault)	Contact capacity: 250 Vac / 2A (cos φ =1), 30 Vdc /1A
		D01_NO		
		D02_NC	Relay output 2 (Run by default)	
		D02_NO		

3.4.4 CT-transformer

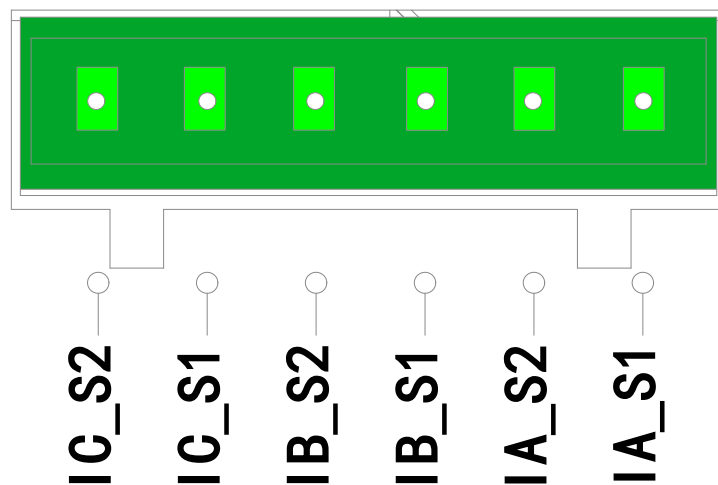



Figure 3-6 The CT port diagram

Interchangeator wiring:

	Terminal symbol	Description of terminal function	Electrical specifications
--	-----------------	----------------------------------	---------------------------

mutual inductor	IC_S2	To the S2 end of the C-phase CT	Transformers 150 / 5~2000 / 5, secondary side rated current 5A It is suggested that the secondary side of the transformer is jointly connected to ensure the accuracy.
	IC_S1	To the S1 end of the C-phase CT	
	IB_S2	To the S2 end of the phase B CT	
	IB_S1	To the S1 end of the phase B CT	
	IA_S2	To the S2 end of phase A CT	
	IA_S1	To the S1 end of the phase A CT	

- (1) Secondary power is greater than 1k V A;
- (2) Accuracy requirement of 0.5 level or above;
- (3) The variable ratio range of CT is: 150 / 5~2000 / 5, and the variable ratio specification is selected according to 1.2~1.5 times of the system current. In actual engineering, it can also be selected according to 1.5 times of the transformer capacity (200 / 400V), for example: the transformer capacity is 2000 kVA, 1.5 times is 30000 / 5;
- (4) The secondary side of CT must be reliable grounding (only one end can be grounded), the transformer cable with shielding double twisted cable (RVVP), 15m with an inner diameter of 2.5mm², 15m~30m line diameter to take 4mm².

 pay attention to	<ul style="list-style-type: none"> ◆ External CT is recommended to be installed on the load side; ◆ Current transformer, as an external accessory of the equipment, plays a vital role in the normal work of the equipment, so the selection of the external current transformer is very important, please be sure to refer to the above instructions for selection; ◆ If the current transformer is not connected correctly, it may cause insufficient filtering effect or equipment failure; ◆ Before installing the current transformer, first short circuit the secondary side and power off the equipment; ◆ Before separating the current transformer and the equipment, it can be short-circuit; ◆ After measuring the load current, there should be a certain allowance for the selection of the transformer.
---	---



warn

- ◆ When the CT wiring, the outlet terminals S1 and S2 of the CT are connected to the positive end (S1) and the negative end (S2) of the CT terminal of the device;
- ◆ The P1 end of the CT is facing the power supply side, and the P2 end is facing the load side;
- ◆ S1 and S2 of each transformer must correspond to the terminals of the corresponding mark, and it is strictly prohibited to open the second twice. Any violation of this article may cause the transformer to burn out;
- ◆ Ensure that the current transformer is short circuit until the CT connection terminals of the equipment are connected.

3.4.3 Single-machine power distribution

Take the load-side sampling as an example:

P1 ← P2 (Transformer facing)

Note: If the direction of the transformer is required, you need to change the "CT direction" in the small screen HMI.

Connect to other bus

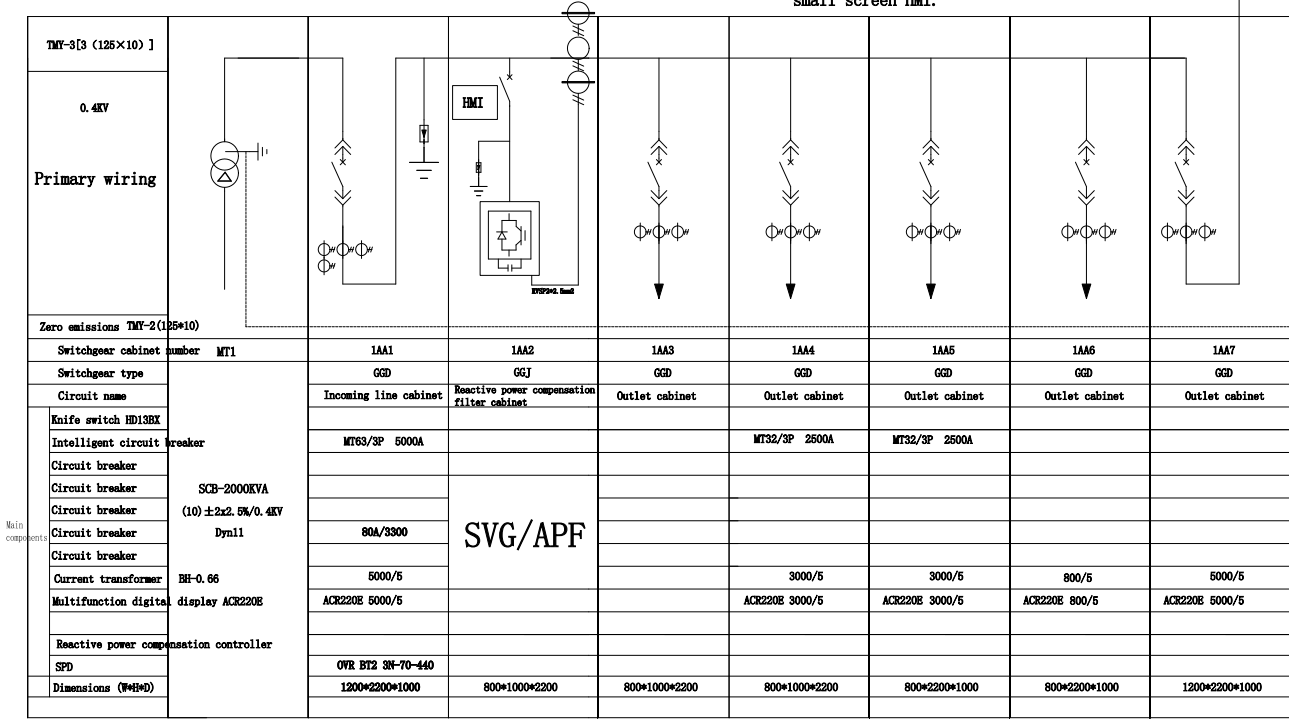

Figure 3-7 Distribution diagram of single unit

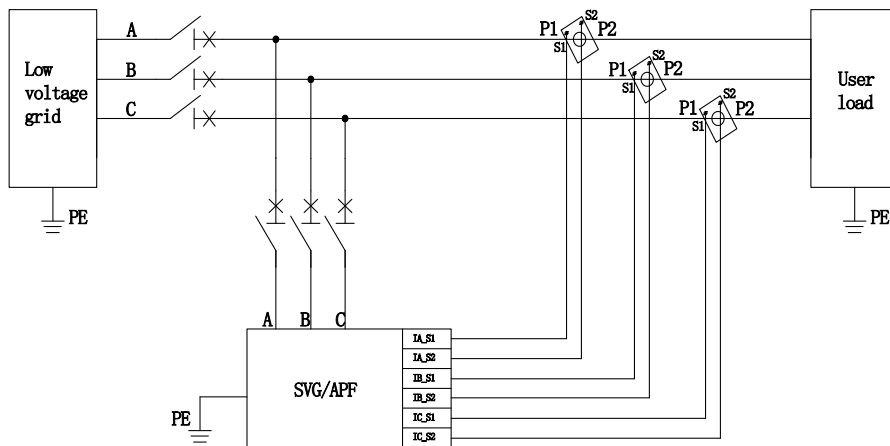

Figure 3-8 Product assembly diagram

It is suggested that the secondary side of the transformer S2 is connected to ensure accuracy.

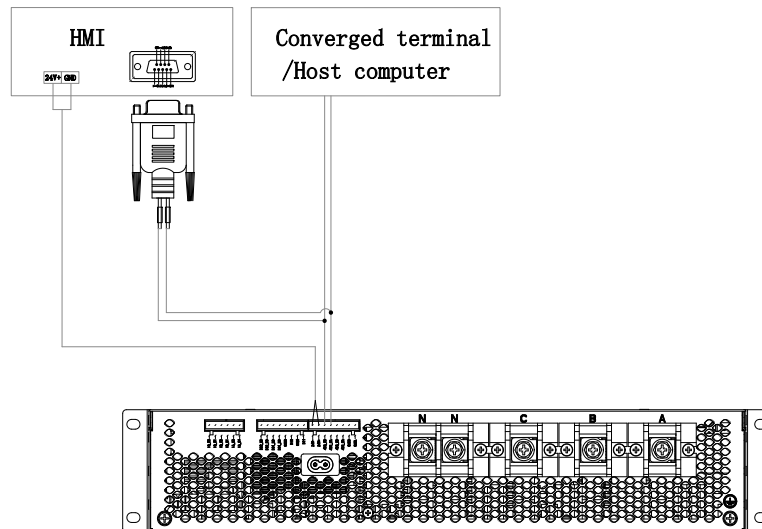



Figure 3-9 Display screen communication diagram

 pay attention to	<ul style="list-style-type: none"> ◆ The circuit diagram shown here is simplified (three phase and four lines), please refer to the physical object; ◆ During single operation, the CT wiring mode of the power side and the load side sampling is consistent; ◆ When the external large screen is connected, DB9 special cable (available) shall be used between the large screen and the module, and connected to RS485 3A_3B (refer to Section 3.4.4); ◆ Large screen power can be external wiring power, but also from the module back DC24V "+, -" terminal wiring power; ◆ With background forwarding communication function is optional content, compared with the wiring without forwarding function, more cable and adapter, our company can provide supporting; ◆ Background forwarding instructions and interface definition are shown in Appendix 1.
---	--

3.4.4 Distribution and distribution

 pay attention to	<ul style="list-style-type: none"> ◆ The power connection is the same as the single machine; ◆ When the power side sampling, two sets of consistent transformer can be installed to do subtraction; ◆ CT side side cable recommended to use series connection method; ◆ When parallel communication, the large screen can take power from the DC24V of one of the modules. ◆ The wiring principle of the cabinet is the same as that of the machine. The wiring between the cabinet can be long with the parallel cable, which is not explained here. For details, please consult our engineer.
---	---

(1) CT load-side sampling

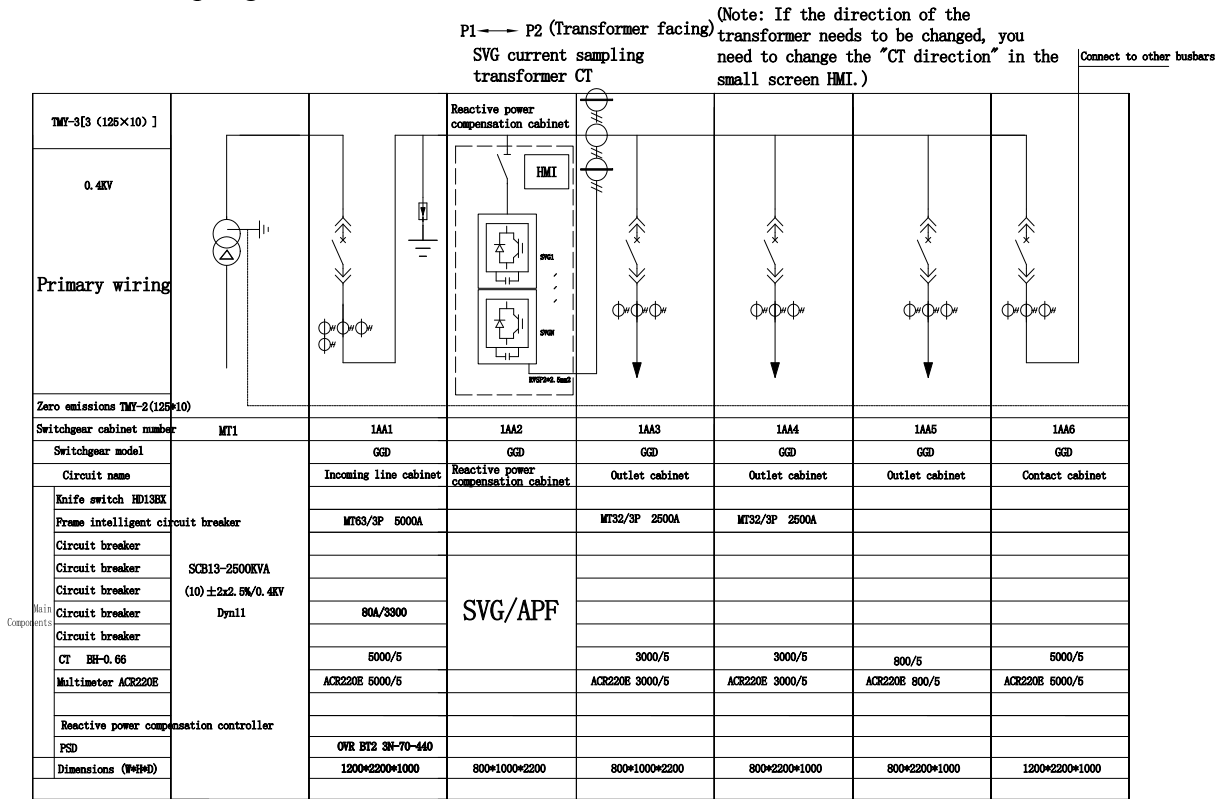

Figure 3-10 Sampling drawing of single-machine power distribution-CT load side

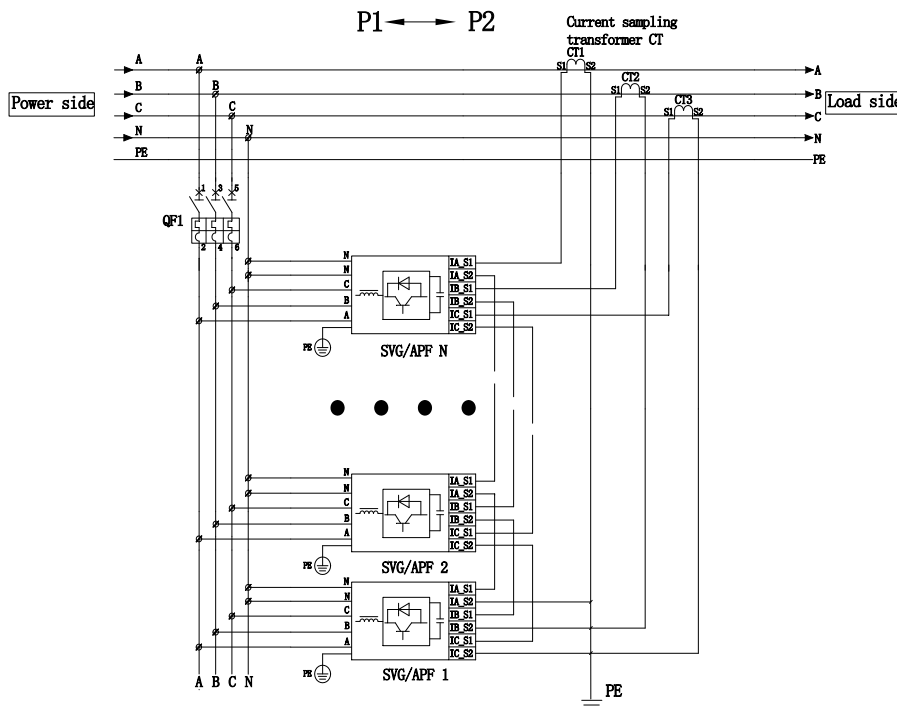

Figure 3-11 Combined distribution-CT load side sampling wiring diagram

(2) The CT power supply side sampling

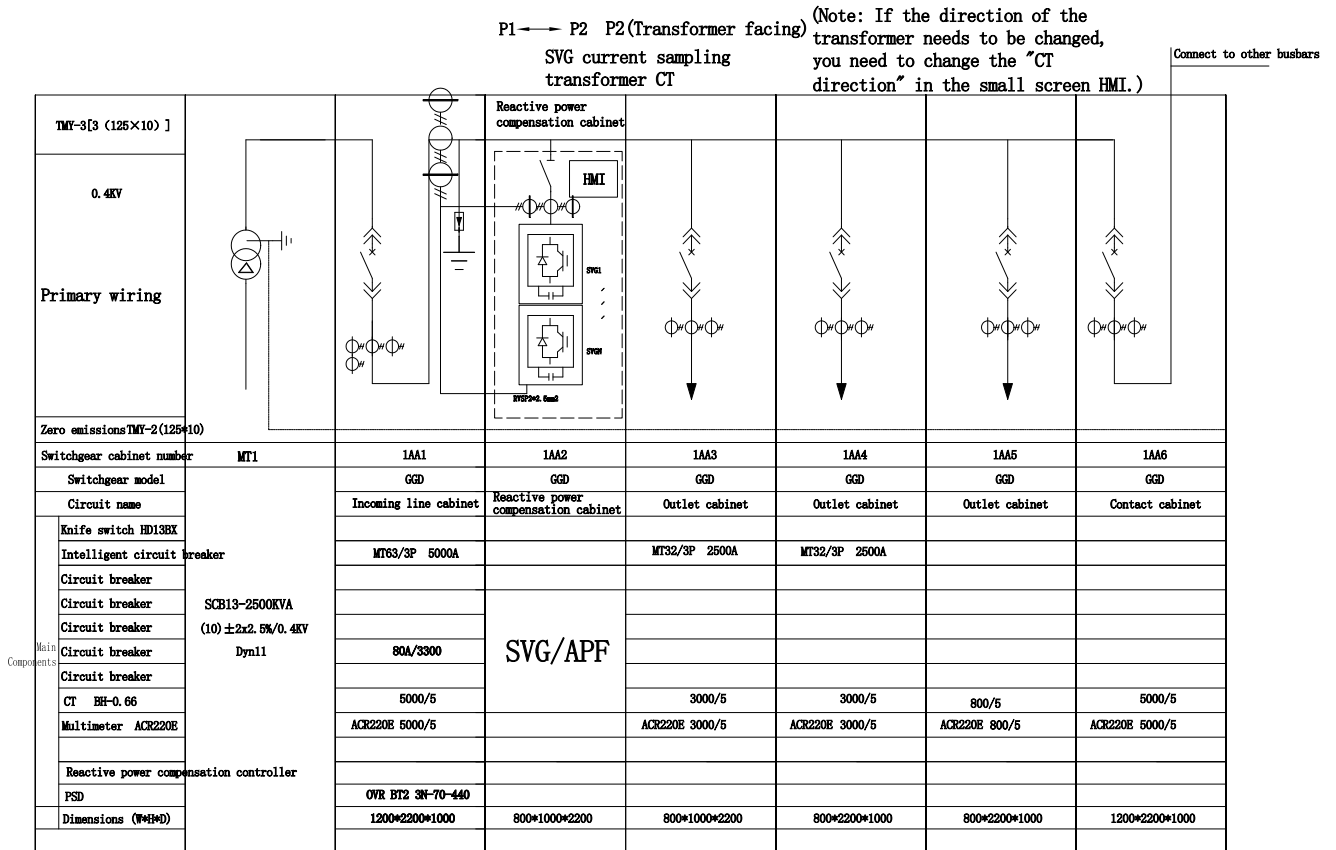

Figure 3-12 Sample drawing of parallel power distribution-CT power supply side

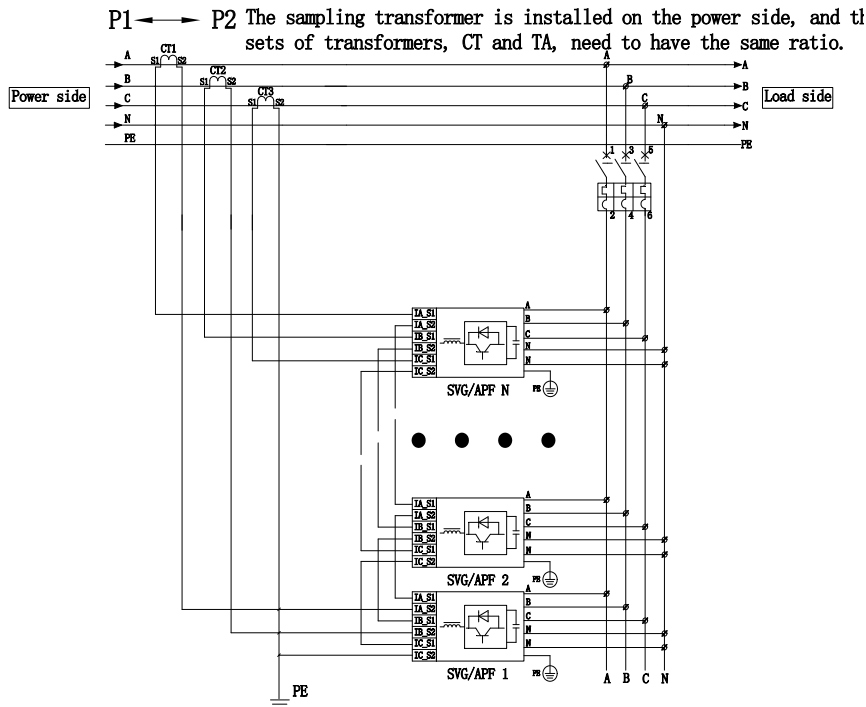

Fig. 3-13 Combined distribution-CT power supply side

(3) Communication wiring

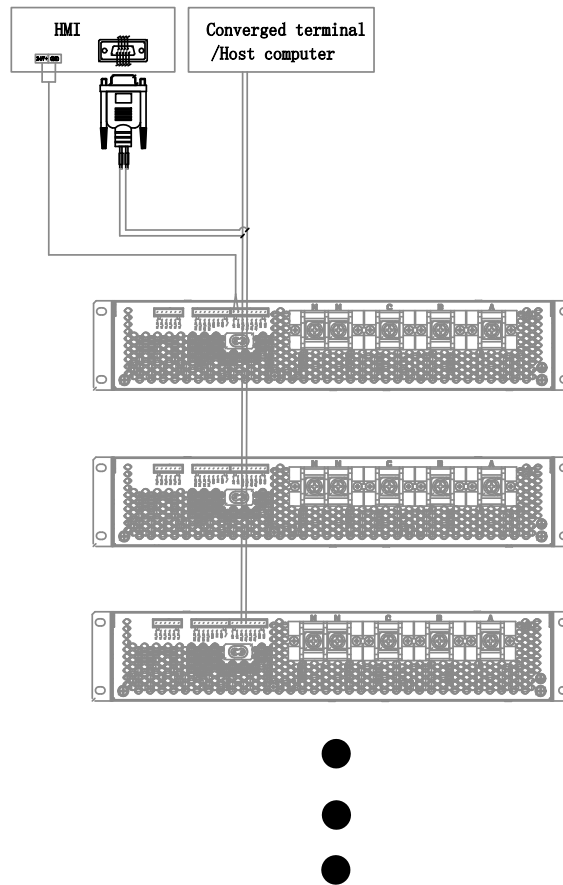



Figure 3-14 Combined machine communication wiring diagram

 <p>pay attention to</p>	<ul style="list-style-type: none"> ◆ For machine connection, the outside of the cabinet is generally equipped with a centralized monitoring screen, and the large screen and the module should be connected with DB9 special cable (available), and the RS485 3A_3B of the first module. ◆ Modules are connected with special lines, and it is recommended to follow the principle of "A versus A and B versus B".
---	--

3.5 Control capacitance

3.5.1 Ordinary capacitor (external relay)

The equipment can control the silicon switching switch (TSC) or contactor through the relay output terminal to realize the switching of the reactive power compensation capacitor. When using the SCR switch scheme, please refer to the following electrical schematic diagram and terminal wiring diagram (16 total fill 16 relays).

Figure 3-15 Schematic diagram of the 12 V drive circuit

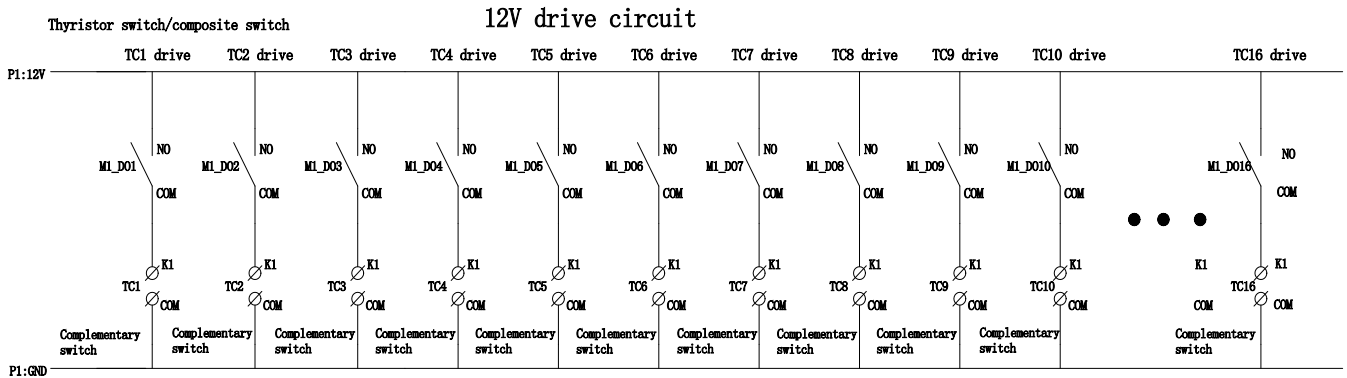

Figure 3-16 220V drive power schematic diagram

220V coil drive circuit

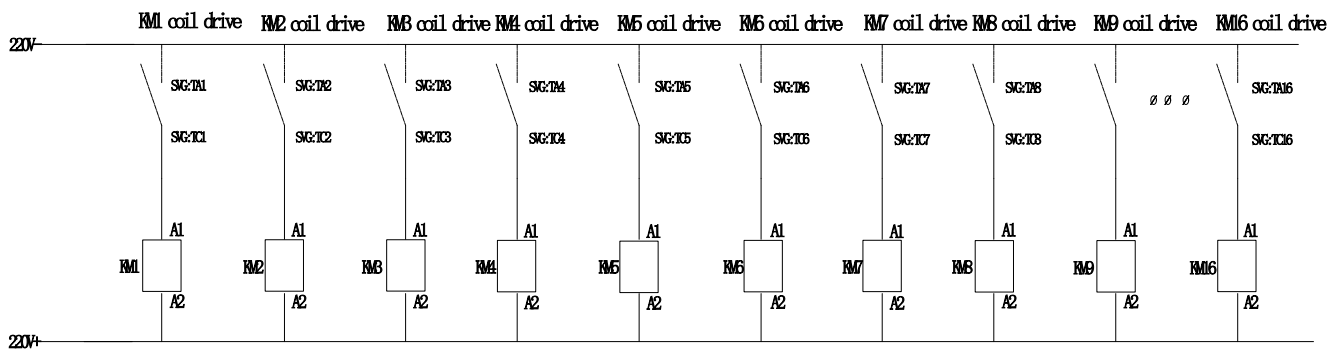
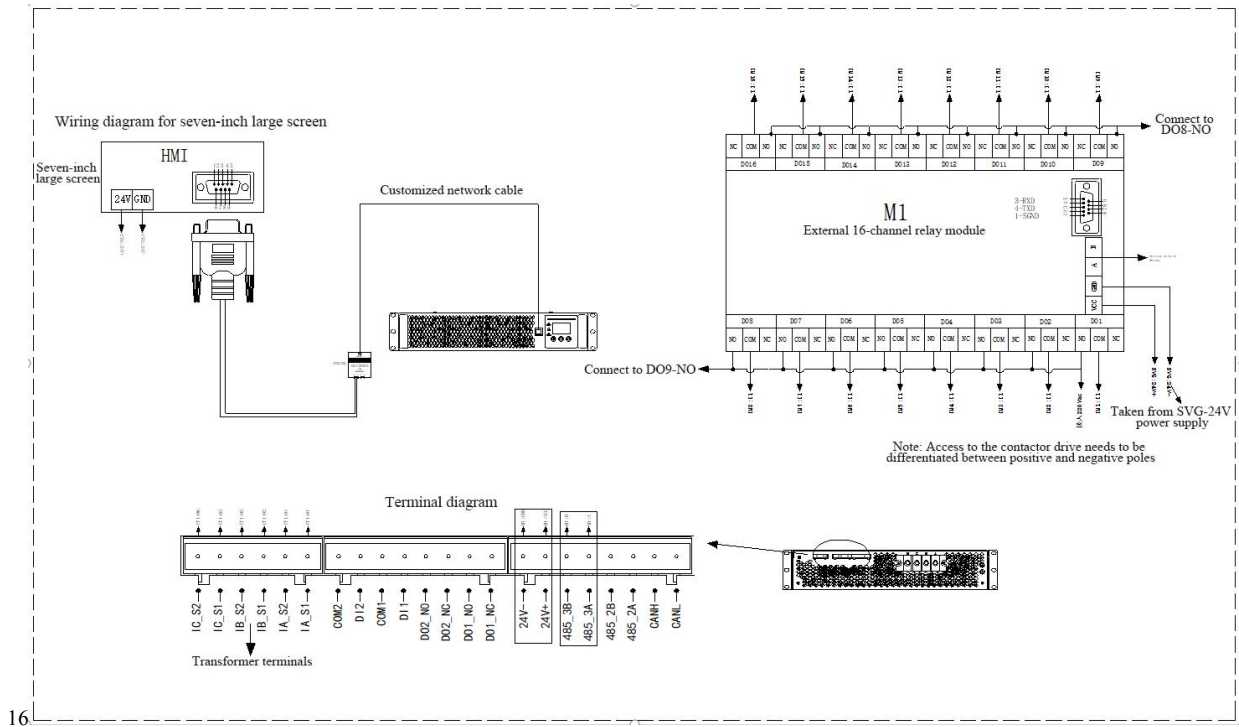

Figure 3-17 Terminal connection diagram of the relay



16

3.5.2 Control the intelligent capacitor

When the equipment is used together with the intelligent capacitor, the external communication connection mode is shown in the figure:

(1) Single-module connection:

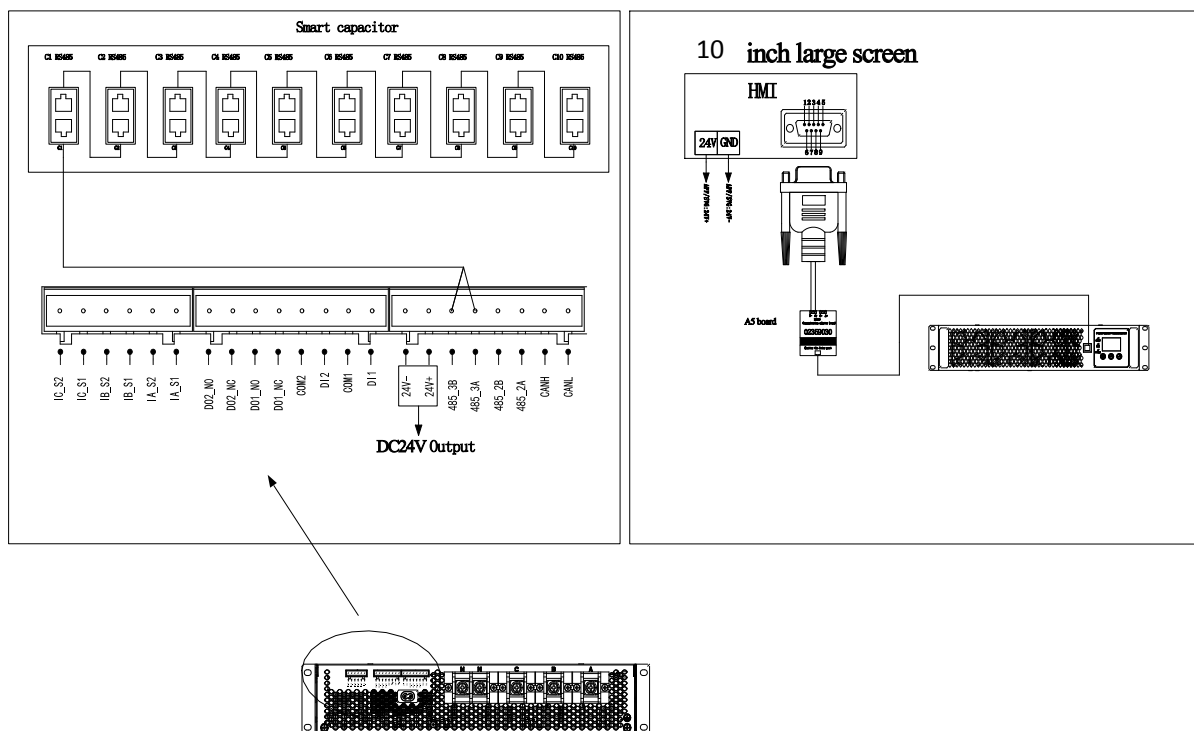

Fig. 3-18 Secondary wiring diagram and communication connection diagram with capacitive RS485

(2) Multiple parallel machine connections:

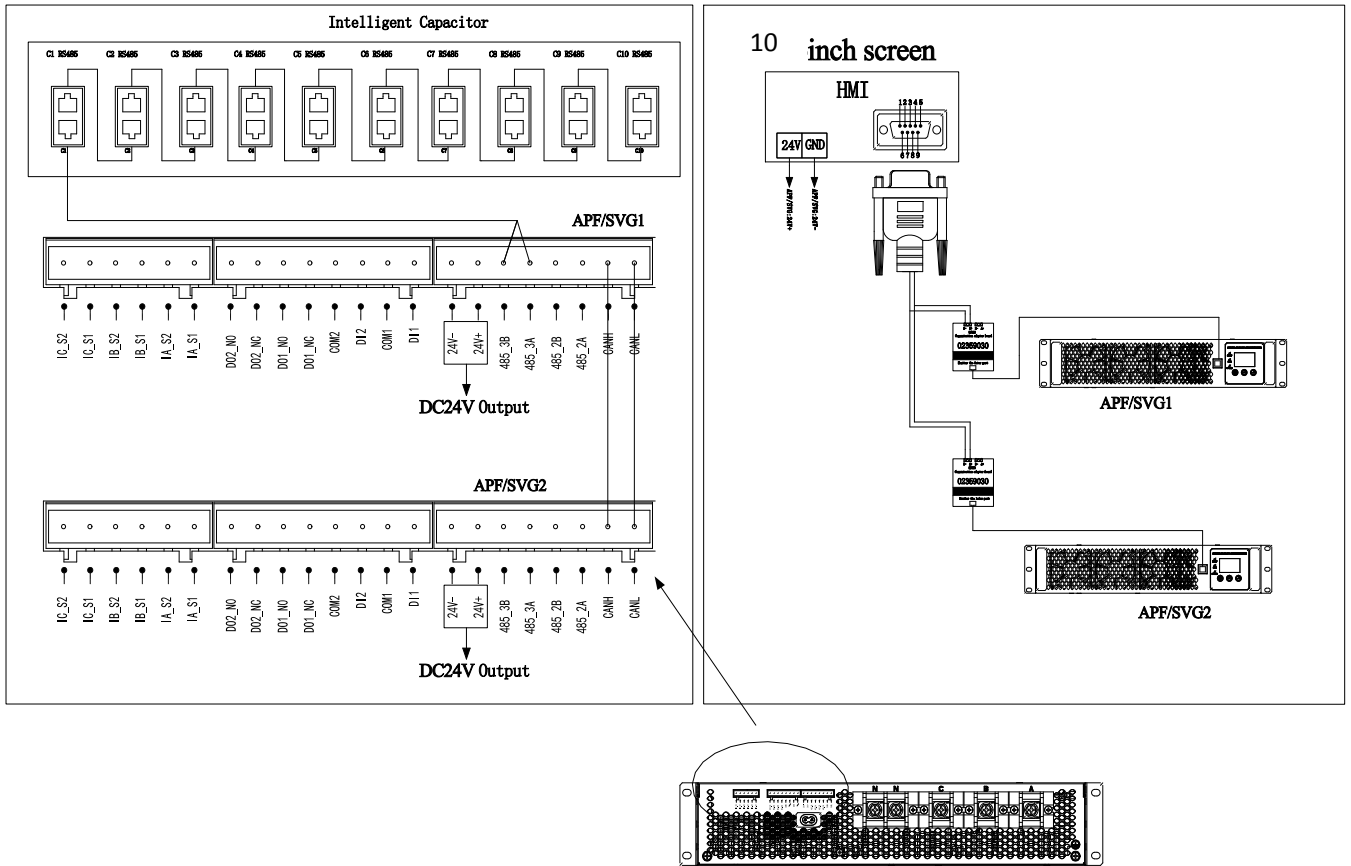

Figure 3-19 Secondary wiring diagram and parallel communication link diagram with capacitor RS485

Fi

Chapter 4: Test run of the single machine

4.1 Check again

Please check the following again before the first power on:

- (1) Whether the equipment is stable and installed on the cabinet (wall) installation column;
- (2) A / B / C / N wiring is correct, whether there is leakage or mixed connection phenomenon;
- (3) Whether A / B / C / N / PE wiring is firm, with hand shaking without displacement or loosening, and PE wiring should be firmly grounded;
- (4) The distance should be maintained, phase spacing not less than 15mm;
- (5) Use the multimeter to detect whether there is A short circuit between the equipment A, B, C and N;
- (6) Check whether the CT wiring is correct and whether the wiring at the terminal row corresponds one to one;
- (7) Check the installation position and installation situation of the current transformer;
- (8) Whether the disconnecting switch is installed correctly and is disconnected;
- (9) The installation environment of the equipment conforms to the contents described in Section 3.2;
- (10) Check whether the phase sequence of the equipment is consistent with that of the power grid, and the input voltage should be the positive phase sequence (ABCN).

4.2 Power on the equipment

After the above check again, close the disconnecting switch between the power supply / grid and the equipment, the display screen is lit and enter the home page, the power supply / POWER indicator of the module is lit and always on, and the external 10-inch screen is displayed as an example (1.8-inch screen has less functions).



Figure 4-1 External 10-inch screen login interface

After ensuring the above error, enter the "switch machine" page, click "boot" (startup time is 30s), and the module starts running. The Run / RUN indicator is on and constantly illuminated with the power / POWER indicator.

After the startup is successful, click "Data" and enter the page to check whether the data of the device

The XBT Series user manual is normal. For example, "CT parameter setting" in the following figure, please check the 7-inch screen operation manual for more displays.

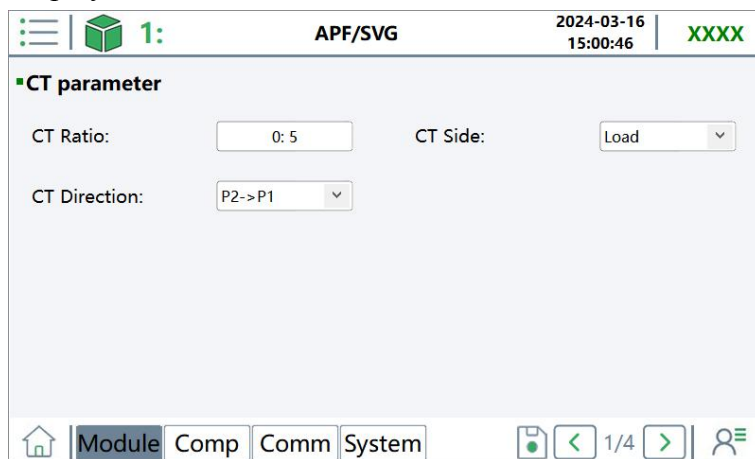

Figure 4-2 External 10-inch screen setting interface

After ensuring that the parameters are correct, enter the "Control" page, click "boot" (the startup time is 30s), and the module starts running. Each parallel module running / RUN indicator is on and on together with the power / POWER indicator. At this time, check whether each module running / RUN indicator is on. If a module with the indicator is not lit, check whether the connected communication line is connected correctly.



Figure 4-3 External 10-inch screen switch interface

After the startup is successful, click "Data" to check whether the "basic", "power" and "harmonics" are normal.

4.3 Equipment is shut down

The shutdown of equipment usually has two steps: shutdown and power off.

4.3.1 Shutdown

That is, enter the "switch" page through the module 1.8 inch screen or external 10 inch large screen, click "Shutdown", the module enters the standby state, the running / RUN indicator is off but the power supply / POWER indicator is always on. This method only makes the module into the low power standby state, and the system bus, auxiliary power supply and main circuit terminal are still charged.

4.3.2 Power-off

After the equipment is shut down and enters the standby state, then disconnect the isolation switch between the equipment and the power supply / grid, so that the operation can stop the equipment and completely power off. When the module needs to be wired or maintained, it should be under power off and shutdown.

*** Do not directly power off the equipment in operation, which will cause some damage to the equipment!**

4.4 Manual / automatic operation

The equipment is started in default manual mode. The manual mode is to manually log in the user interface and click the startup operation. The automatic mode can automatically start up after the module is powered on. The user can switch to the automatic mode in the equipment standby state according to the actual demand.

Chapter 5 Trial operation

The installation of the parallel module will generally be equipped with a 7-inch large cabinet screen. For operation details, please refer to the 10-inch large screen user manual. No detailed explanation is given here.

5.1 Check again

Please check the module one by one before the first power-on, including the installation environment, installation position, wiring, etc. In addition, it is necessary to check whether the communication wiring between the 10-inch large screen and the first module is correct, and whether the positive and negative poles of the large-screen power cord are mixed.

5.2 Power on the equipment

After the above inspection is correct, close the disconnecting switch between the city and the equipment, the 10-inch large screen and module 1.8-inch LCD LCD are lit, the power supply / POWER indicator of the module is on and always on, check whether the power supply / POWER indicator of each parallel module is lit, at this time the module is in "standby" state.

Log in to senior users of 10-inch screen, enter the home page, and check whether the data parameters such as the voltage and current on the grid side, output side and load side of each parallel module are normal.

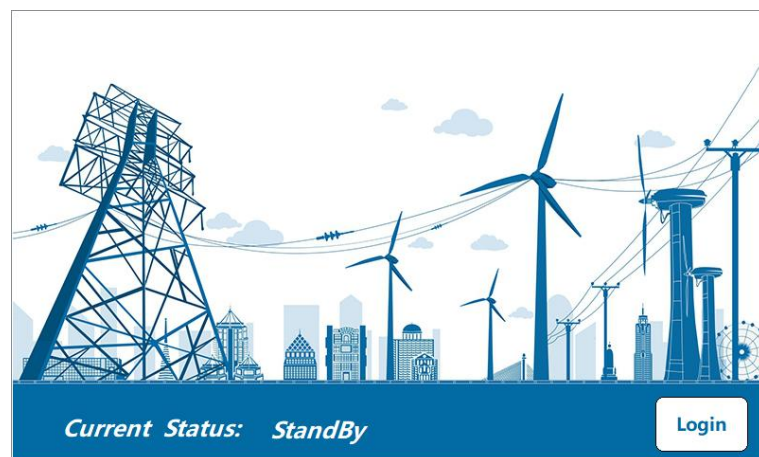

Figure 5-1 First interface of the large screen

Then enter the setting page to see whether the CT change ratio, CT position, CT direction, operation mode, parallel capacity and other setting parameters are correct. At this point, switch the parallel module to observe whether the data of each module is normal and consistent with the setting parameters. If this fails, check the wiring and modify the parameters through the large screen operation (operate under the guidance of the engineer).

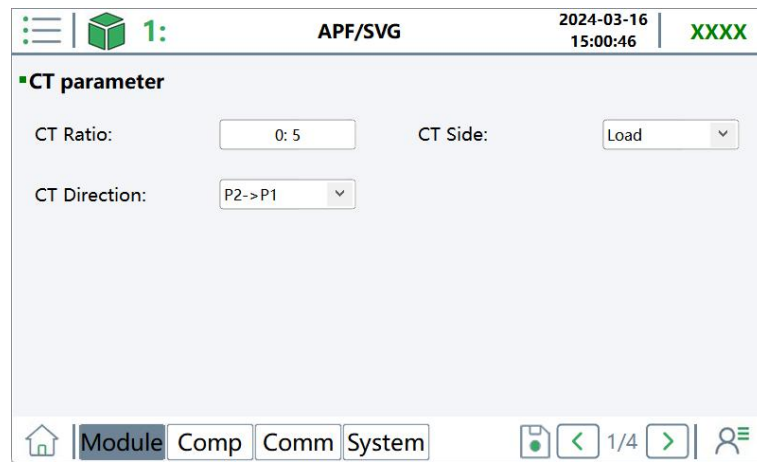

Figure 5-2 Large screen

After ensuring that the parameters are correct, enter the "Control" page, click "boot" (the startup time is 30s), and the module starts running. Each parallel module running / RUN indicator is on and on together with the power / POWER indicator. At this time, check whether each module running / RUN indicator is on. If a module with the indicator is not lit, check whether the connected communication line is connected correctly.



Figure 5-3 Large-screen control interface

After the startup is successful, click "Data" to check whether the "basic", "power" and "harmonics" are normal.

5.3 Equipment is shut down

The parallel equipment shutdown generally has two steps: shutdown and power off.

(1) Shutdown

That is, through the 10-inch screen of the module, enter the "switch" page, click "Shutdown", all parallel modules enter the standby state, the running / RUN indicator is off but the power / POWER indicator is still on. This method only makes the module into the low power standby state, and the system bus, auxiliary power supply and main circuit terminal are still charged.

(2) Power failure

After the equipment is shut down and enters the standby state, then disconnect the isolating switch between each unit of the equipment and the power supply / power grid, so that the equipment can stop

The XBT Series user manual running and completely power off. When the module needs to be wired or maintained, it should be in a state of power shutdown.

*** Do not directly power off the equipment in operation, which will cause some damage to the equipment!**

5.4 Manual / automatic operation

The equipment is started in default manual mode. The manual mode is to manually log in the user interface and click the startup operation. The automatic mode can automatically start up after the module is powered on. Users can switch to automatic mode under standby state according to actual requirements. Please refer to the 10-inch user manual for no additional instructions here.

Chapter 6 A 1.8-inch screen menu

The module body 1.8-inch button screen, can also be customized according to the requirements without display models.

The screen can display the voltage, current, power and other information on the current grid side and the load side, as well as the state of the equipment, and can set the parameters through the screen button.

The key screen is shown in Figure 4-1. Key ">>" is to exit or return to the previous interface; "" is to turn down or modify the parameter value on the parameter setting page; "↵" is to confirm after entering or after the parameter is modified.

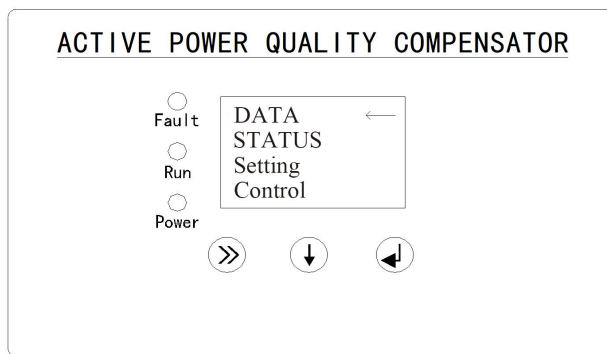

Figure 4-1 Schematic diagram of LCD button screen

The following table details the parameters and meanings displayed in each page.

Table 4-1 Screen display parameters and significance

page	The parameter name	Parameter meaning	attribute	
data	Grid data	Power grid voltage	A / B / C effective voltage value of each phase	read only
		Power grid current	A / B / C effective current value of each phase	read only
		Voltage harmonic	A / B / C power grid voltage THDu in each phase	read only
		current harmonics	A / B / C power grid voltage of each phase THDi	read only
		power factor	A / B / C power factor of the grid side of each phase	read only
		active power	A / B / C active power at the power grid side of each phase	read only
		reactive power	A / B / C reactive power on the grid side of each phase	read only
		apparent output	A / B / C Each phase power grid side view at the power	read only
		Power grid	Current grid frequency	read only

page	The parameter name	Parameter meaning	attribute	
		frequency		
		Power grid phase order	Current grid phase order	read only
	Load data	current effective value	A / B / C Effective value of the load current of each phase	read only
		current harmonics	A / B / C load harmonic current THDi for each phase	read only
		power factor	A / B / C The power factor of the load side of each phase	read only
		active power	A / B / C The active power of the load side of each phase	read only
		reactive power	A / B / C The reactive power of the load side of each phase	read only
		apparent output	A / B / C Each phase load side view at the power	read only
		Equipment data	output	The module output current
	Module temperature		The IGBT temperature inside the module	read only
	busbar voltage		The DC bus voltage inside the module	read only
	electric relay		Relay status	read only
	The main DSP version		Primary DSP software version	read only
	The auxiliary DSP version		Auxiliary DSP software version	read only
	FPGA edition		FPGA software release	read only
	HMI edition		HMI software release	read only
	unit type		The model number displayed by the equipment	read only
	Fill up the data	Fill up the data	Automatically query the online co-complement capacitor data	read only
	Divide the data	Divide the data	Automatic query online supplement capacitor data	read only
	state	move	The module is in the operation state	read only
await the opportune moment		The module is in the standby state	read only	
hitch		The module is in a fault state and displays the fault word	read only	
set up	Manufacturer parameters	Enter the manufacturer's password to enter	read-write	
	CT no-load voltage ratio	According to the variable ratio setting	read-write	

page	The parameter name	Parameter meaning	attribute
		of the external transformer	
	CT position	Set up the CT is installed on the grid side or on the load side	read-write
	CT direction	Set the CT orientation, P1P2 or P2P1→→	read-write
	DspModbus Address	Set the correspondence address of the DSP	read-write
	LcdModbus Address	Set the mailing address of the LCD screen	read-write
	WifiModbus Address	Set the correspondence address for the WiFi	read-write
	And machine capacity	Set the total capacity of the parallel system	read-write
	Start mode	Set up a manual boot or an automatic boot	read-write
	Allow phase order	Sets the allowed phase sequence when the module runs	read-write
	Power grid overpressure point	Set up the power grid overvoltage point of the module	read-write
	Module compensation capacity	The compensated capacity of the module body	read-write
	Reduction coefficient	Set the coefficient of the module	read-write
	mode of connection	Set three phase three or three phase four	read-write
	switching frequency	Set the IGBT opening-breaking frequency	read-write
	electric current loop KP	Set the current ring control coefficient	read-write
	Repeat control coefficient	Set the current repetition control factor	read-write
	Power grid crossing point	Set up the module output overcurrent protection point	read-write
	Harmonic perflow point	Set up the module resonance overcurrent protection point	read-write
	Zero line crossing point	Set up the module zero-line overcurrent protection point	read-write
	The system is overtemperature	Set up the module over-temperature protection point	read-write
	Fan high speed current	Set the fan running at high speed of the current	read-write

page	The parameter name	Parameter meaning	attribute
	Fan low speed current	Set the fan low-speed running current	read-write
	Fan high speed temperature	Set the fan high-speed running temperature	read-write
	Fan low speed temperature	Set the fan running temperature	read-write
	Capacitive operation mode	Set the capacitance to run automatically or manually	read-write
control	starting up	Manual boot	read-write
	shut down	Manual shutdown	read-write
	reset	Manual reset of the fault information	read-write
	Curing parameters	Saves the set parameters	read-write

Note: Factory parameters are only for debugging by authorized personnel, and improper use by non-authorized personnel may lead to module damage!

Chapter 7 Cabinet 10-inch HMI

The LCD 10-inch HMI is installed on the front side of the active filter cabinet door and comes in two different sizes. Users can monitor the active filter cabinet through HMI, read and set the modified equipment parameter data, which is an optional item. Please contact our professional technicians for the detailed operation information of 10-inch HMI!

The two different opening sizes of the 7-inch HMI are 215 * 152mm and 192 * 138mm, respectively. Generally, 215 * 152mm hole size screen is selected by default. If you need to choose 192 * 138mm hole size screen, please note in advance.

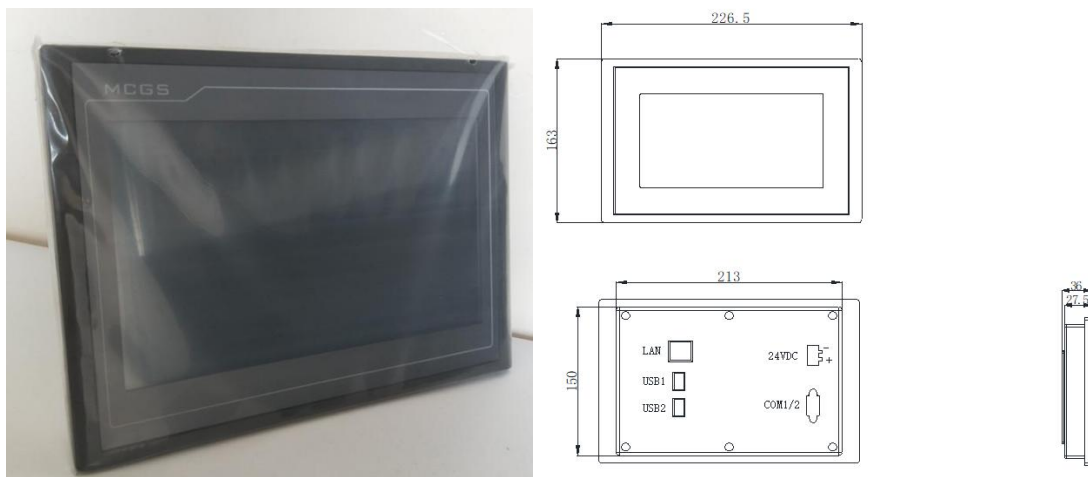



Figure 7-1 215 * 152 Open large screen

product features		peripheral interface	
LCD	10Inch TFT	serial interface	COM1 (RS232), COM2 (RS485), scalable (COM3, COM4)
Backlight	LED	USB joggle	1 Main 1 from
input voltage	DC: 24V±20%	CAN joggle	open end
power rating	5W	Ethernet port	nonsupport
attestation		ambient condition	
product certification	CE/FCC	Storage temperature	-10~60℃
levels of protection	The IP65 front panel	working temperature	0~45℃
electromagnetic compatibility	Industrial level 3	Working humidity	5%~95%
		size of product	
		Case material	Industrial plastic
		Panel size	226.5*163 (mm)
		Open hole size	215*152 (mm)

*** In addition, we can provide a large 10-inch HMI screen, with the recommended cabinet opening size of 261 * 180mm.**

Chapter VIII Maintenance and Maintenance

In order to ensure the normal and safe operation of the equipment, we recommend the regular maintenance of the equipment.

 danger	◆ Beware of electric shock, pay attention to protection!
---	--

8.1 Attention before maintenance

- (1) The equipment is running with strong electricity, and for the sake of safety, the maintenance personnel shall not touch any part of the equipment during the operation of the equipment;
- (2) Due to the large number of capacitance of the equipment bus, the maintenance work must be carried out 15 minutes after the power failure;
- (3) After the power supply is disconnected, a warning sign should be set at the disconnected place to prevent someone from being on in the maintenance process;
- (4) In order to avoid accidental risks, the maintenance personnel should wear insulation equipment during the maintenance process;
- (5) Personnel with professional and technical qualifications are required to maintain the equipment.

8.2 Content and cycle of daily maintenance

Maintenance project	Maintain the content	Recommended time
routine inspection	Need to equipment Input, output voltage and current and operating state for real-time monitoring, observe whether it is within the normal range;	q.d
	Check whether the air inlet and outlet are unobstructed;	
	Read the internal temperature of the device and observe the normal range.	
Status check	check upequipment Whether the appearance is damaged or rusty;	half a month
	hearequipment Whether there is an abnormal sound when running, smell whether there is a peculiar smell;	
	Check whether the ambient humidity, temperature, dust and ventilation conditions around the equipment meet the requirements.	
Cable inspection	Check whether the cable and terminals are damaged;	trimester
	Whether the main circuit wiring, grounding wire and communication wiring are reliably connected;	
	Check whether there are aging and burning marks at the wiring bolts, and shake it with the hand to confirm whether it is tightened.	

Note: When the equipment is stored for more than half a year, it needs to start up for 1 hour.

8.3 Complete maintenance steps

Step 1: Check the surrounding environment

(1) Test the temperature and humidity of the current environment with professional instruments to ensure that it is within the normal range;

(2) Remove the debris around the module and keep it dry.

Step 2: Shut off

(1) Disconnect the disconnecting switch and power off the equipment;

(2) Wait at least 15 minutes for the capacitor in the module to fully discharge.

Step 3: Clean the equipment

(1) Check whether the surface of the equipment is damaged or missing;

(2) Visual check whether the cable is deformed or damaged;

(3) Clean up the dust and debris on the surface of the equipment, and pay attention to the cleaning in the air outlet for foreign body blockage.

Step 4: Check the disconnecting switch

(1) Check whether the isolating switch is aging and damaged.

Step 5: Check the mechanical installation / electrical connection

(1) Check whether the installation screws at all mechanical connections are firm, and clean up the dust above;

(2) Check whether the electrical wiring is firm, and the cable can be properly strengthened or replaced.

Step 6: Other abnormalities

(1) For example, if the internal cable is damaged, please contact the technical personnel of the manufacturer in time.

Step 7: Restart the device

(1) Restore all cable connections and check;

(2) Close the isolation switch and start the equipment;

(3) Check the parameters;

(4) Start-up and operation.

Chapter 9. Common troubleshooting

order number	Fault name	processing method
1	EPO hitch	Check whether the emergency stop switch button is pressed, reset the button switch or click the reset switch on the small screen; if not solved, please contact the professional technicians of the manufacturer!
2	The IGBT hardware overflows	Reset or restart boot,If not solved, please contact the professional and technical personnel of the manufacturer!
3	Bus hardware overpressure	Click the small screen data interface to view the equipment data bus voltage V, the normal module standby bus voltage is about 650, if out of the scope, please contact the manufacturer professional technical personnel!
4	Overflow of module hardware	Check whether the CT installation direction is consistent with the setting, and whether the CT secondary wiring is reverse. If not solved, please contact the professional and technical personnel of the manufacturer!
5	Auxiliary power failure	This fault occurs, please contact the professional technicians of the manufacturer to solve it!
6	Fan fault	Check whether the fan is running normally, if the fan is not replaced, the normal operation can be reset before starting. If not solved, please contact the professional technicians of the manufacturer!
7	Single board connection failure	Click reset or restart boot,If not solved, please contact the professional and technical personnel of the manufacturer!
8	Melt damage	Click reset or restart boot,If not solved, please contact the professional and technical personnel of the manufacturer!
9	The power module is too warm	Check whether the ambient temperature is too high, whether the inlet and outlet of the system are smooth. If everything is normal, it can be reset and then boot. If not solved, please contact the professional and technical personnel of the manufacturer!
10	Voltage A / AB overvoltage	Confirm whether the input voltage is normal, if not solved, please contact the manufacturer professional technician!

11	Voltage B / BC overvoltage	Confirm whether the input voltage is normal, if not solved, please contact the manufacturer professional technician!
12	Voltage A / AC overvoltage	Confirm whether the input voltage is normal, if not solved, please contact the manufacturer professional technician!
13	Voltage A / AB undervoltage	Confirm whether the input voltage is normal, if not solved, please contact the manufacturer professional technician!
14	Voltage B / BC undervoltage	Confirm whether the input voltage is normal, if not solved, please contact the manufacturer professional technician!
15	Voltage C / CA undervoltage	Confirm whether the input voltage is normal, if not solved, please contact the manufacturer professional technician!
16	Power grid overfrequency	Confirm whether the input voltage frequency is in the range of 40.5~62.5Hz. If this range is the system misalarm, please contact the professional technical personnel of the manufacturer.
17	Power grid underfrequency	Confirm whether the input voltage frequency is in the range of 40.5~62.5Hz. If this range is the system misalarm, please contact the professional technical personnel of the manufacturer.
18	Power grid phase inversion	Check whether the phase sequence and allowable phase sequence are correct. If not, please contact the professional technical personnel of the manufacturer!
19	A phase flow	Reduce the input current value of the power grid, if not solved, please contact the professional technicians of the manufacturer!
20	B phase flow	Reduce the input current value of the power grid, if not solved, please contact the professional technicians of the manufacturer!
21	C phase flow	Reduce the input current value of the power grid, if not solved, please contact the professional technicians of the manufacturer!
22	Pre-charging bus overvoltage	Click reset shutdown, disconnect the circuit and adjust the bus for power,If not solved, please contact the professional and technical personnel of the manufacturer!
23	Pre-charging bus is undervoltage	Click reset shutdown, disconnect the circuit and adjust the bus for power,If not solved, please contact the professional and technical personnel of the manufacturer!

24	Uncontrolled rectified bus undervoltage	Click the reset shutdown, disconnect the circuit and restart the circuit switch, If not solved, please contact the professional and technical personnel of the manufacturer!
25	Run the bus overpressure	Confirm whether the bus voltage is normal, if not solved, please contact the professional and technical personnel of the manufacturer!
26	Running bus underpressure	Confirm whether the bus voltage is normal, if not solved, please contact the professional and technical personnel of the manufacturer!
27	Plus and minus bus line imbalance	Check whether the N line is connected, if not solved, please contact the professional technicians of the manufacturer!
28	Background communication protocol error	Check whether the connection between the module and the large screen is normal. If not solved, please contact the professional and technical personnel of the manufacturer!
29	EEPROM hitch	Click reset restart boot, if not solved, please contact the manufacturer professional and technical personnel!
30	Auxiliary DSP failure	Click reset restart boot, if not solved, please contact the manufacturer professional and technical personnel!
31	Synchronous phase locking between DSP s	Click reset restart boot, if not solved, please contact the manufacturer professional and technical personnel!
32	System resonance	Click reset restart boot, if not solved, please contact the manufacturer professional and technical personnel!
33	The module does not communicate with the large screen	Check whether the communication line is connected, whether the positive and negative electrode of the 24V power line is connected, and whether the wiring screw is tightened. If not solved, please contact the professional and technical personnel of the manufacturer!

*** Only common faults and response methods are listed here. In case of other unknown faults, please contact professional manufacturers in time!**

appendix:

Background forwarding description and interface definition

The background forwarding function is a function that sends the device data collected on the large screen to other receiving devices through a customized cable. At present, only "one-to-one" forwarding is supported, that is, the data sent by a large screen can only be received by one device (upper computer, background terminal, etc.).

(1) Large-screen forwarding

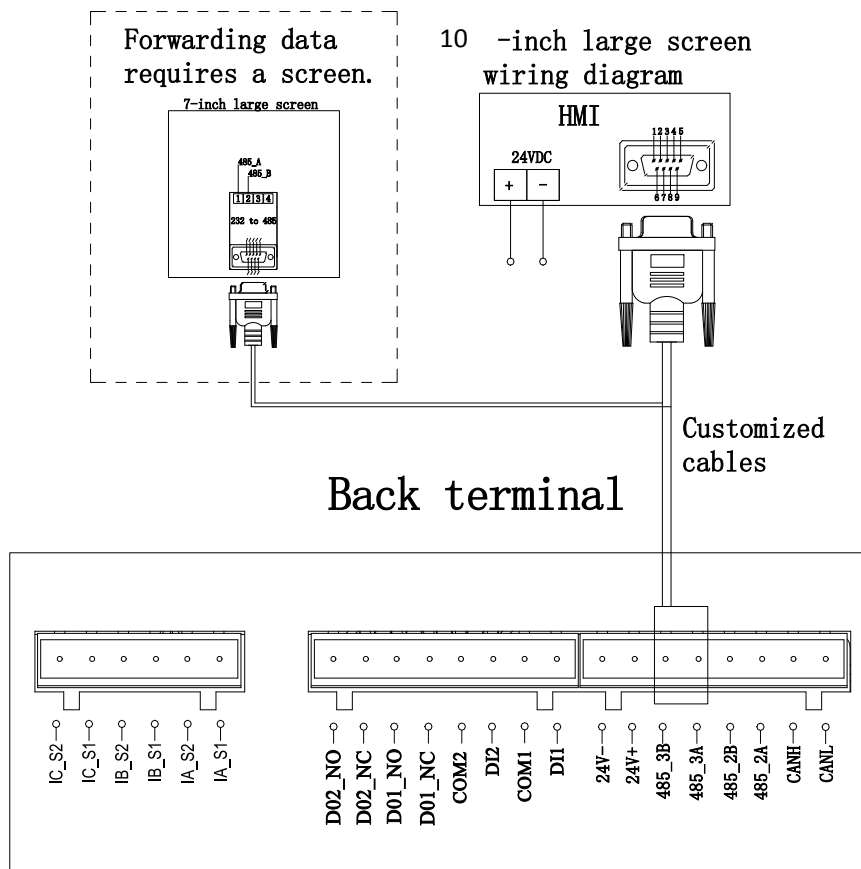

When data is forwarded through the large screen, the master interface of the large screen can be connected through the DB9 head at one end of the cable, the other end to the RS485 3A_3B of the device (refer to Section 3.4.3), and a set of 485 signals on the large screen can be connected to the upper computer or the background terminal through the adapter.